

BICAR^{med}

The technology
that revolutionizes
the cleaning of
Reusable Medical
Devices

STK100

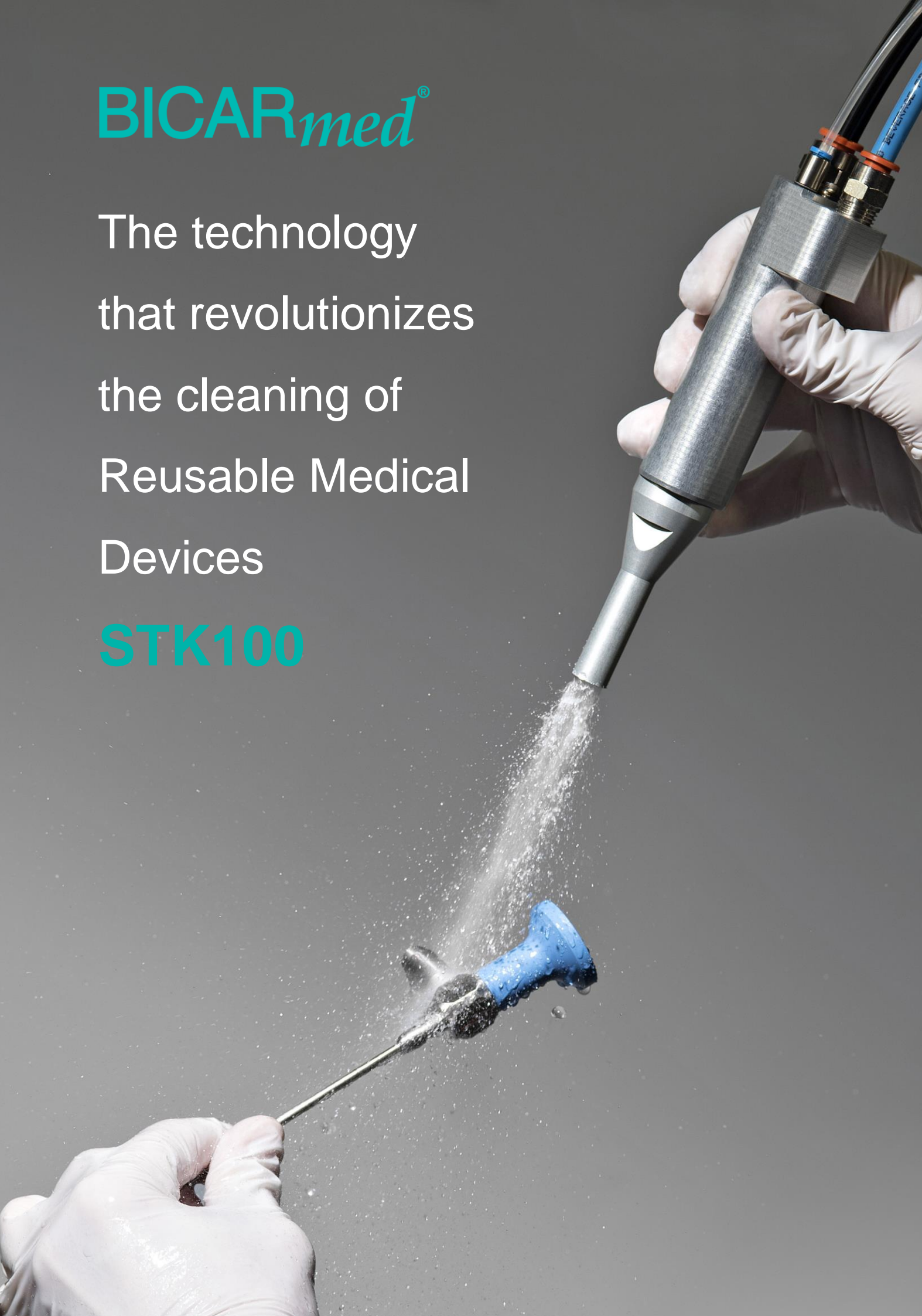



BICAR *med*[®] is the revolutionary cleaning technology using sodium bicarbonate that overcomes all washing challenges



UNIQUE

One way to pre-washing all instruments: endoscopic optics, motor drills, canulas, fragile instruments, generic and specialized instruments.



SAFE

The treatment **does not damage the protection** of the instruments and is performed into a closed cabin thus **avoiding operator contact with dangerous contaminants**.



EFFECTIVE

Maximum removal of difficult compounds like dirt, bone, cements, cauterized blood, even on geometrically complex surfaces.



ECONOMICAL

Significant **reduction on maintenance of RMDs**. **Wear prevention** by oxidation, corrosion, pitting and biofilm **extending RMDs' lifecycle**.

*You can clean without sterilizing
but you can not sterilize without cleaning.*
Spaulding, 1957



Proper cleaning of Reusable Medical Devices (RMD) is essential to obtain sterility.

UNI EN 556 international Standard states that **it is not sufficient for an instrument to appear visually clean to guarantee the absence of surface residues.**

Even more so, a visibly dirty instrument cannot be considered sterile with the safety level required by the standard. Since it's impossible to visually establish the threat and nature of contaminants, any residue that makes the device **visibly unclean, must be considered unacceptable.**

Proper RMDs cleaning is of such importance that today's methods of cleaning RMDs must be improved upon. In particular, RMDs that are difficult to clean present challenges that are not being met by today's traditional washing methods.

CHALLENGES

1

CRITICAL TOOLS TO CLEAN

(RMDs with complex shapes and geometries)

2

DIRT DIFFICULT TO REMOVE

(cauterized blood, cements, glues, overheated bonded, etc.)

In particular, RMDs that are difficult to clean present challenges that are not being met by today's traditional washing methods.

In these cases you have to apply specific treatments for each type of challenge, which can be damaging to the devices, as well as dangerous for the operator.

BRUSHING

ABRASIVE PASTE

AIR-STEAM
TREATMENT

SOLVENTS

BICAR_{med}[®]: the unique sodium bicarbonate process:

With four international patents registered and recognized, SAFE CleanBox is the revolutionary cleaning solution of the Reusable Medical Devices developed by BICAR_{med}[®] after eight years of research, tests and collaboration with leading Italian Universities and national and foreign health facilities.

SAFE CleanBox is a medical device that uses SAFE_{Klinik}[®], sodium bicarbonate in granules, and low pressure compressed air. The flow of bicarbonate and air, conveyed through a handpiece, strikes the surface of the instrument uniformly and continuously. The dirt is thus removed in depth, even from the most complex geometries and with the most adherent contaminants.

Through a second handpiece it is possible the complete rinsing of the tool.

The mechanical action of the granules has no abrasive effects: the kinetic energy is absorbed by the granule itself which, after the impact with the surfaces to be cleaned, is destroyed.

SAFE_{Klinik}[®] sodium bicarbonate is noncorrosive, completely soluble, and biodegradable. Therefore, it does not pollute the environment and it is safe for operators.

TRADITIONAL CLEANING PROCESS

PHASE 1
PRE-WASH:
MANUAL, ULTRASOUND
AND / OR OTHER



PHASE 2
WASHER
DISINFECTOR

CLEAN
INSTRUMENTS

42,1%*

BICARMED CLEANING PROCESS

PHASE 1
PRE-WASH:
BICAR_{med}[®]



PHASE 2
WASHER
DISINFECTOR

CLEAN
INSTRUMENTS

98,2%*

* Data are taken from tests carried out according to Annex N of the ISO / TS 15883-5 standard, evaluating BICAR_{med}[®]'s cleaning effectiveness on five particular RMD: Poole suction tube, micro-invasive soul forceps, micro-invasive handle forceps, trocar, hemostatic forceps.

BICAR^{med} technology guarantees maximum effectiveness in cleaning of:

CRITICAL TOOLS

TOOLS WITH COMPLEX SHAPES AND GEOMETRIES AS:

ENDOSCOPIC TOOLS

CANNULATED TOOLS

ORTHOPEDIC TOOLS

ELECTROSURGERY TOOLS

DELICATE MICROSURGERY TOOLS

RIGID OPTICS

ROBOTIC TOOLS

NOT-SUBMERSIBLE TOOLS

CRITICAL DIRT

HEAVY DIRT

DRY DIRT

RESIDUES FROM CAUTERIZATION PRACTICES

INORGANIC RESIDUES

BONE RESIDUES

CEMENT RESIDUES

GLUE RESIDUES

Better protection, operator safety

- Closed cabin to isolate the working area
- No contact with dangerous contaminants
- Cut resistant gloves

Better cleaning, patient safety

- Nozzle for cleaning with baking soda and for rinsing with pressurized water
- Specific tips for cleaning the cannulas
- Glass with magnifying glass
- Specific baking soda granulometry to be more effective without scratching RMD surfaces

Clean RMDs, less maintenance and replacement costs

BICAR^{med} technology:

- Removes and prevents the biofilm deposition
- Reduces maintenance by eliminating the surface oxidations as well as the inorganic residues
- Maintains unaltered the tool surface protection layer for the durability benefit

Efficiency in detail:



Detail of a laparoscopic forceps before BICARmed[®] treatment



Detail of the same forceps after BICARmed[®] treatment

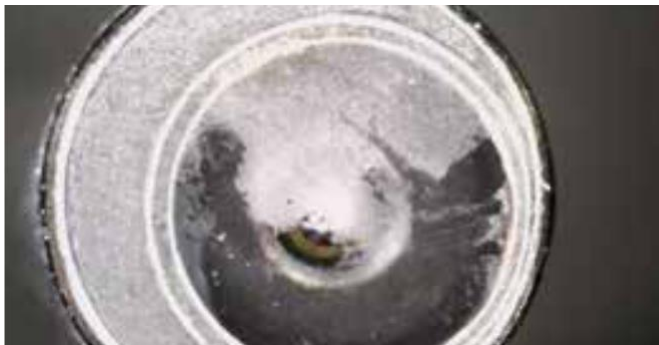

Detail of an optic before BICARmed[®] treatment

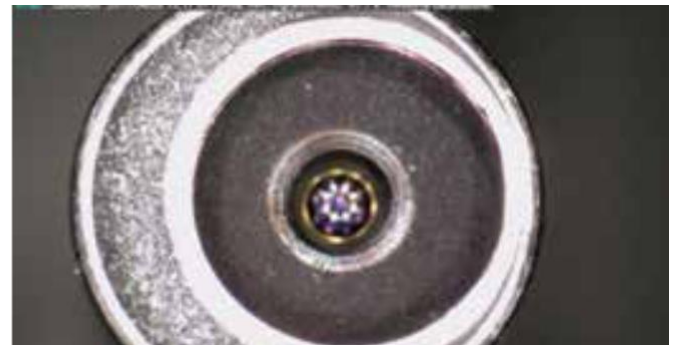

Detail of the same optics after BICARmed[®] treatment

Quality of result:

An effective cleaning prevents the accumulation of debris deposits on the instruments' surface, thus reducing instrument damage from oxidation. Oxidation creates micro holes on RMD surfaces over time (pitting), of difficult, if not impossible, cleanliness, which weakens instruments leading them to early breakage. Therefore, preventing oxidation will extend the average lifespan of RMDs.

Practical use:

The touch keypad inside the cabin allows the operator to easily perform all cleaning, rinsing, and loading / unloading operations, as well as, automatic cabinet door opening / closing operations.

All instruments can be cleaned with the same technology, comfortably seated, without wasting of time.

Features

- MADE IN AISI 304 STEEL
- BICARBONATE NOZZLE
- RINSING NOZZLE
- FLANGES FOR REMOVABLE GLOVES
- GLASS WITH MAGNIFYING GLASS
- RFID READER
- ID OPERATOR CARD

Connection features

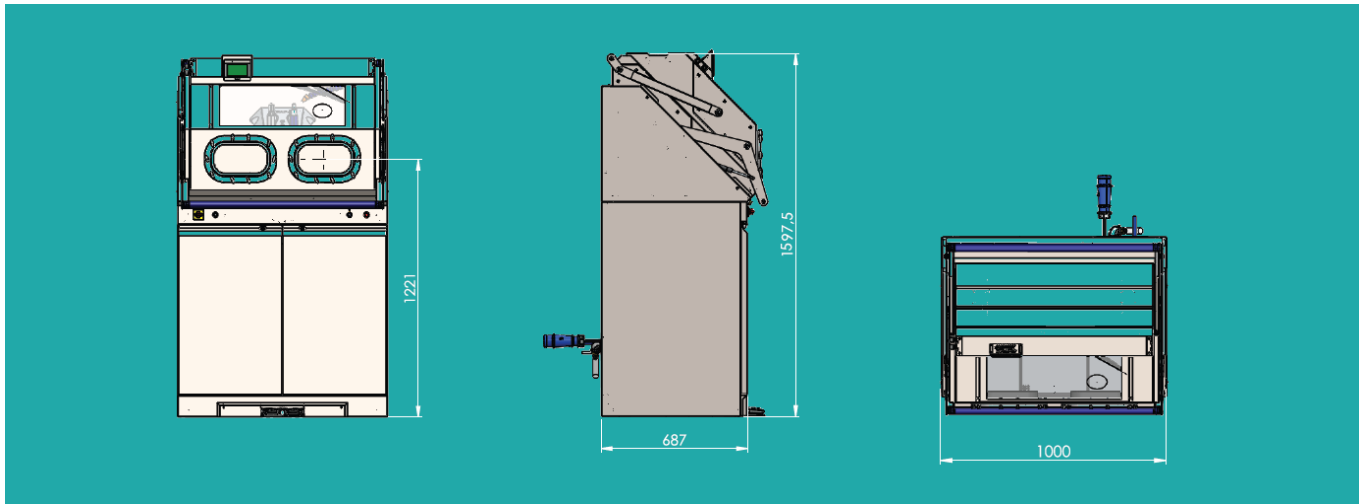

| MEASUREMENTS | CONNECTION FEATURES |
|--|---|
| <p>Dimensions: 1000 x 687 mm</p> <p>Height: 1597.5 mm</p> <p>Weight: 320 Kg</p> <p>Drainpipe: diameter 40 mm</p> | <p>Power supply: 220/230 V; 50/60 Hz; 10A/ 2,3 kW</p> <p>Air supply: 6 bar (min) - 8 bar (max) DN 15 mm (1/2")</p> <p>Water supply: 3 bar (min) – 6 bar (max.) DN 15 mm (1/2")</p> <p>Connection to the discharge of industrial waste water not dangerous.</p> |

Certifications and patents

SAFE CleanBox is CE certified and marked as a Class I Medical Device, in compliance with European Directive 2017/745/EEC.

BICAR_{med}[®] holds 4 registered and recognized patents.

BICAR_{med}[®]

Medical Division of BICARJET SRL
Via Nona Strada 2 - 35129 - Padova, ITALY
+39 049 780 8036
info@bicarmed.com
www.bicarmed.com

